

OWNERS MANUAL

PAGURO 9000 v

PAGURO 12000 v

MARINE DIESEL GENERATOR

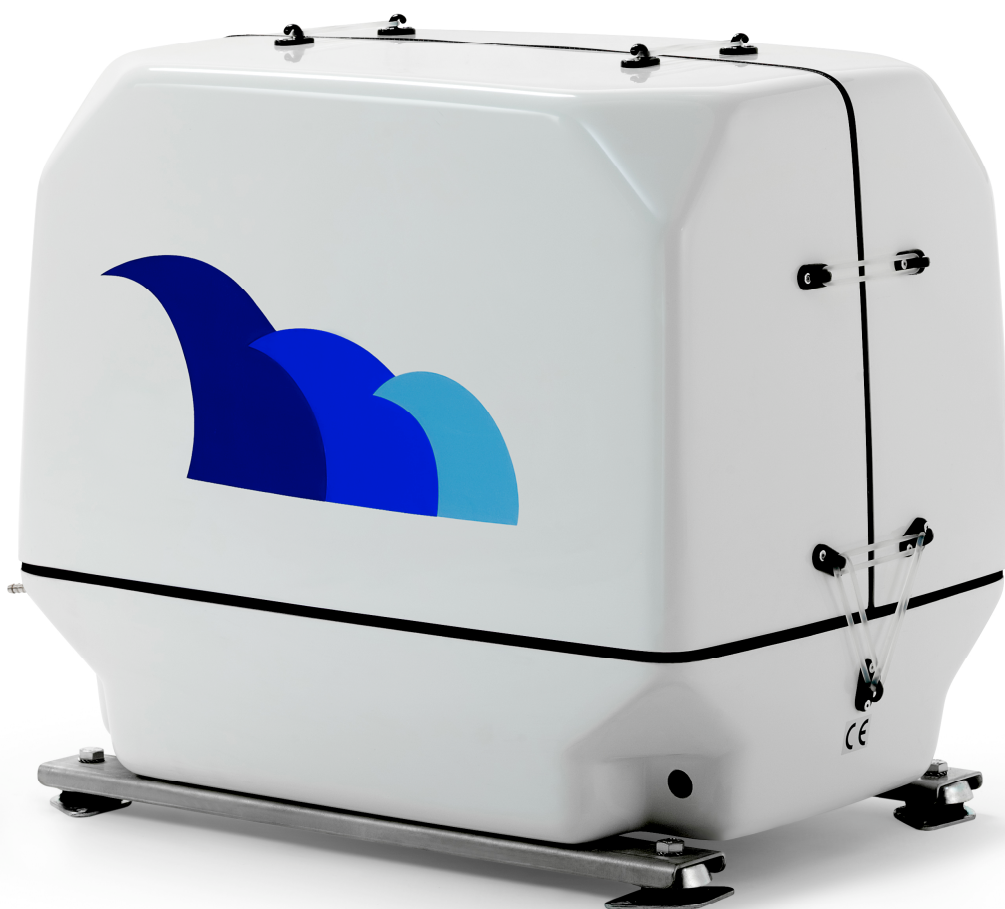

We thank you for the confidence you have shown in us, by purchasing the **PAGURO** for fitting in your boat. The target of our design, to achieve a diesel unit with the power usually supplied in a small flat, in a compact size and light weight, is completely reached. So there is not the need to waste a large room in your boat, and even if the chosen place is away from the centre line of the boat, the reduced weight of the **PAGURO** will not influence the stability.

TECHNICAL SPECIFICATION AND PERFORMANCES

		<i>PAGURO 9000 v</i>	<i>PAGURO 12000 v</i>
Diesel engine maker		Lombardini Marine, Italy	Lombardini Marine, Italy
Engine type / cylinders n.		LDW 702 / 2 cyl.	LDW 1003 / 3 cyl.
Continuous speed (rpm)	50 Hz	2000 - 3000	2000 - 3000
	60 Hz	-	-
Specific fuel consumption		0.35 lt./KW/h	
Cooling system		Fresh water with heat exchanger	
Cooling pump		Johnson system self-priming directly driven, without belt	
Starting system		12 V Electrical starter remote controlled	
Alternator maker		V.T.E. - Italy	
Generator type		PMG AC generator	
Electric continuous power	50 Hz	9 KVA - 8 KW	12 KVA - 10 KW
	60 Hz		
Voltage	50 Hz	230	
	60 Hz	-	
Auxiliary voltage for starting battery		12 V - 8 A	
Remote control		fitted with hourmeter, load indicator, automatic shut off device for low oil pressure and water over temperature, starting motor self disengagement, 15 m cable and socket	
Peak current for 2 sec. (230 V)		65 A	80 A
Noise level a 7 mtrs.		50 -53 dB (A)	
Weight, capsule included (kgs)		150	170
Weight of the electronic box (kgs)		15	15

**CALIFORNIA
PROPOSITION 65 WARNING**

Diesel engine exhaust and some of its constituents are known to the State of California to cause cancer, birth defects, and other reproductive harm

 **WARNING**

Exhaust gasses contain Carbon Monoxide, an odorless and colorless gas. Carbon Monoxide is poisonous and can cause unconsciousness and death.

Symptoms of Carbon Monoxide exposure can include:

- **Dizziness**
- **Nausea**
- **Headache**
- **Weakness and sleepiness**
- **Throbbing in temples**
- **Muscular twitching**
- **Vomiting**
- **Inability to think coherently**

IF YOU OR ANYONE ELSE EXPERIENCE ANY OF THESE SYMPTOMS GET OUT INTO THE FRESH AIR IMMEDIATELY. If symptoms persist, seek medical attention. Shut down the unit and do not restart unit until it has been inspected and repaired.

SAFETY INSTRUCTIONS

INTRODUCTION

Read these safety instructions carefully. Most accidents are caused by failure to follow fundamental rules and precautions. Know when dangerous conditions exist and take the necessary precautions to protect yourself, your personnel and your machinery.

The following safety instructions are in compliance with the American Boat and Yacht Council (ABYC) standards.

PREVENT ELECTRIC SHOCK

WARNING:

Do not touch AC electrical connections while engine is running, or when connected to shore power. Lethal voltage is present at these connections!

- Do not operate this machinery without electrical enclosures and covers in place.
- Shut-off electrical power before accessing electrical equipment.
- Use insulated mats whenever working on electrical equipment.
- Make sure your clothing and skin are dry, not damp (particularly shoes) when handling electrical equipment.
- Remove wristwatch and all jewelry when working on electrical equipment.
- Do not connect utility shore power to vessel's AC circuits, except through a ship-to-shore double throw transfer switch. Damage to vessel's AC generator may result if this procedure is not followed.
- Electrical shock results from handling a charged capacitor. Discharge capacitor by shorting terminals together with an insulated tool.

PREVENT BURNS - HOT ENGINE

WARNING:

Do not touch hot engine parts or exhaust system components. A running engine gets very hot!

WARNING:

Steam can cause injury or death!

- In case of an engine overheat, allow the engine to cool before touching the engine or checking the coolant.

PREVENT BURNS – FIRE

WARNING:

Fire can cause injury or death!

- Prevent flash fires. Do not smoke or permit flames or sparks to occur near the fuel line, filter, fuel pump, or other potential sources of spilled fuel or fuel vapors. Use a suitable container to catch all fuel when removing the fuel line or fuel filters.
- Keep the compartment and the engine / generator clean and free of debris to minimize the chances of fire. Wipe up all spilled fuel and engine oil.
- Be aware – diesel fuel will burn.

PREVENT BURNS – EXPLOSION

WARNING:

Explosion from fuel vapors can cause injury or death!

- Follow re-fueling safety instructions. Keep the vessel's hatches closed when fueling. Open and ventilate cabin after fueling. Check below for fumes / vapor before running the blower. Run the blower for four minutes before starting your engine.
- All fuel vapors are highly explosive. Use extreme care when handling and storing fuels. Store fuel in a well-ventilated area away from spark-producing equipment and out of the reach of children.
- Do not fill the fuel tank(s) while the engine is running.
- Shut off the fuel service valve at the engine when servicing the fuel system. Take care in catching any fuel that might spill. DO NOT allow any smoking, open flames, or other sources of fire near the fuel system or engine when servicing. Ensure proper ventilation exists when servicing the fuel system.
- Do not alter or modify the fuel system.
- Be sure all fuel supplies have a positive shutoff valve.
- Be certain fuel line fittings are adequately tightened and free of leaks.
- Make sure a fire extinguisher is installed nearby and is properly maintained. Be familiar with its proper use. Extinguishers rated ABC by the NFPA are appropriate for all applications encountered in this environment.

ACCIDENTAL STARTING

! WARNING:
Accidental starting can cause injury or death!

- Disconnect the battery cables before servicing the engine/generator. Remove the negative lead first and reconnect it last.
- Make certain all personnel are clear of the engine before starting.
- Make certain all covers, guards, and hatches are re-installed before starting the engine.

BATTERY EXPLOSION

! WARNING:
Battery explosion can cause injury or death!

- Do not smoke or allow an open flame near the battery being serviced. Lead acid batteries emit hydrogen, a highly explosive gas, which can be ignited by electrical arcing or by lit tobacco products. Shut off all electrical equipment in the vicinity to prevent electrical arcing during servicing.
- Never connect the negative (-) battery cable to the positive (+) connection terminal of the starter solenoid. Do not test the battery condition by shorting the terminals together. Sparks could ignite battery gases or fuel vapors. Ventilate any compartment containing batteries to prevent accumulation of explosive gases. To avoid sparks, do not disturb the battery charger connections while the battery is being charged.
- Avoid contacting the terminals with tools, etc., to prevent burns or sparks that could cause an explosion. Remove wristwatch, rings, and any other jewelry before handling the battery.
- Always turn the battery charger off before disconnecting the battery connections. Remove the negative lead first and reconnect it last when servicing the battery.

BATTERY ACID

! WARNING:
Sulfuric acid in batteries can cause severe injury or death!

- When servicing the battery or checking the electrolyte level, wear rubber gloves, a rubber apron, and eye

protection. Batteries contain sulfuric acid which is destructive. If it comes in contact with your skin, wash it off at once with water. Acid may splash on the skin or into the eyes inadvertently when removing electrolyte caps.

TOXIC EXHAUST GASES

! WARNING:
Carbon Monoxide (CO) is a deadly gas!

- Ensure that the exhaust system is adequate to expel gases discharged from the engine. Check the exhaust system regularly for leaks and make sure the water-injected exhaust elbow is securely attached.
- Be sure the unit and its surroundings are well ventilated.
- In addition to routine inspection of the exhaust system, install a carbon monoxide detector. Consult your boat builder or dealer for installation of approved detectors.
- For additional information refer to ABYC T-22 (educational information on Carbon Monoxide).

! WARNING:
Carbon Monoxide (CO) is an invisible gas. Inhalation produces flu-like symptoms, nausea or death!

- Do not use copper tubing in diesel exhaust system. Diesel fumes can rapidly destroy copper tubing in exhaust systems. Exhaust sulfur causes rapid deterioration of copper tubing resulting in exhaust/water leakage.
- Do not install exhaust outlet where exhaust can be drawn through portholes, vents, or air conditioners. If the engine exhaust discharge outlet is near the waterline, water could enter the exhaust discharge outlet and close or restrict the flow of exhaust. Avoid overloading the craft.
- Although diesel engine exhaust gases are not toxic as exhaust fumes from gasoline engines, carbon monoxide gas is present in diesel exhaust fumes. Some of the symptoms or signs of carbon monoxide inhalation or poisoning are:
 - Vomiting
 - Muscular twitching
 - Dizziness
 - Intense headache
 - Throbbing in temples
 - Weakness and sleepiness

AVOID MOVING PARTS

 **WARNING:**
Rotating parts can cause injury or death!

- Do not service the engine while it is running. If a situation arises in which it is absolutely necessary to make operating adjustments, use extreme care to avoid touching moving parts and hot exhaust system components.
- Do not wear loose clothing or jewelry when servicing equipment; tie back long hair and avoid wearing loose jackets, shirts, sleeves, rings, necklaces or bracelets that could be caught in moving parts.
- Make sure all attaching hardware is properly tightened. Keep the protective shields and guards in their respective places at all times.
- Do not check fluid levels while the engine is operating.

HAZARDOUS NOISE

 **WARNING:**
High noise levels can cause hearing loss!

- Never operate an engine without its muffler installed.
- Do not run engines for long periods with their enclosures open.

 **WARNING:**
Do not work on machinery when you are mentally or physically incapacitated by fatigue!

EC DECLARATION OF CONFORMITY

Manufacturer: **VOLPI TECNO ENERGIA SRL**

Address: **Via Petronio 1/C – 34015 – Muggia (TS)**

The undersigned Riccardo Snaidero as Volpi Tecno Energia general manager declares that the generator model:

Code	Model
AP09023050M0	PAGURO 9000 V
AP12023050M0	PAGURO 12000 V

Corresponds to the requirements of the following EEC Directives:

- 89/392/EEC (as amended by the Directive 91/368/EEC and 93/44/EEC)
- 89/336/EEC (as amended by the Directive 92/31/EEC)
- 73/23/EEC (as amended by 93/68/EEC)

Volpi Tecno Energia

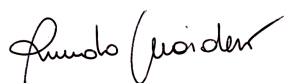

Riccardo Snaidero
General Manager

TABLE OF CONTENTS

–	GENERAL INFORMATIONS	3
–	SAFETY INSTRUCTIONS	5
–	INTRODUCTIONS / RECOMMISSIONINGS	10
1.	INSTALLATION	11
	EXTERNAL CONNECTIONS	12
	VENTILATION	12
	LOCATION AND MOUNTINGS	13
	FUEL LINES (Fuel Supply Line, Fuel return Line)	13
	EXHAUST SYSTEM	13
	RAW WATER COOLING SYSTEM (Siphon break, Raw Water Intake)	15
	INVERTER INSTALLATION	16
	STARTING BATTERY CONNECTION	16
	MAIN OUTPUT VOLTAGE (230 V AC)	16
	CONTROL PANEL	17
2.	PREPARATION FOR INITIAL START-UP	18
	DIESEL FUEL	18
	ENGINE OIL SPECIFICATION	18
	PRE-START INSPECTION	18
3.	STARTING/STOPPING PROCEDURE	19
	ELECTRIC START	19
	PRE-HEATING	19
	STARTING OPERATION	19
	OPERATING THE GENERATOR	19
	INITIAL START UP CHECK LIST	19
	STOPPING THE GENERATOR	19
4.	BREAK-IN PROCEDURE	20
	CHECK LIST	20
	STOPPING THE GENERATOR	20
5.	MAINTENANCE SCHEDULE	21
6.	EXHAUST SYSTEM	23
	EXHAUST SYSTEM PRECAUTIONS	23
7.	COOLING SYSTEM	24
	RAW WATER PUMP (inspecting/changing the raw water pump impeller)	24
	RAW WATER INTAKE STRAINER	24
8.	LUBRICATION SYSTEM	25
	ENGINE OIL	25
	OIL PRESSURE	25
	OIL COOLER	25
	OIL FILTER	25
	CHECKING THE OIL	25
	CHANGING THE OIL	25
	DRAINING THE USED OIL	25
	ADDING NEW OIL	26
9.	FUEL SYSTEM	26
	DIESEL FUEL	26
	FUEL ADDITIVES	26
	CARE OF THE FUEL SUPPLY	26
	FUEL LIFT PUMP	26
	FUEL FILTER	26
	FUEL SUPPLY LINE	27
	FUEL FILTER OF THE WATER-SEPARATING TYPE	27
	FUEL INJECTION PUMP	27
	FUEL SHUT-OFF SOLENOID	27
	BLEEDING THE FUEL SYSTEM	27
	SPARE PARTS	27
10.	ENGINE TROUBLESHOOTING	28
11.	DC ELECTRICAL SYSTEM	29
	CONTROL PANEL	29
	12 VOLT DC CONTROL CIRCUIT	30
	BATTERY (Battery Care, Checking the service Battery)	30
	ELECTRICAL SCHEME	31
12.	GENERATOR INFORMATION	32
	GENERATOR MAINTENANCE	32
13.	GENERATOR TROUBLESHOOTING	32
14.	SHORE POWER TRANSFER SWITCH	32
15.	LAY UP AND RECOMMISSIONING	33

INSTALLATION

When installing PAGURO generators, it is important that strict attention be paid to the following information:

CODES AND REGULATIONS

Please follow the basic safety rules, when installing generators in a marine environment.

SIPHON-BREAK

For installation where the external shock absorbers close to or will be below the vessel's waterline, provisions **must** be looped a minimum of 50 cm above the vessel's waterline. **Failure to use a siphon-break when the external shock absorbers are at or below the load waterline will result in raw water damage to the engine and possible flooding of the boat.**

If you have any doubt about the position of the external shock absorbers relative to the vessel's waterline under any of the vessel's various operating conditions or when the vessel is not underway, **install a siphon-break**. This precaution is necessary to protect your engine.

NOTE: *A siphon-break requires periodic inspections and cleaning to ensure proper operation. Failure to properly maintain a siphon-break can result in catastrophic engine damage. Consult the siphon-break manufacturer for a proper maintenance schedule.*

EXHAUST SYSTEM

The exhaust hose must be certified for marine use. The system must be designed to prevent water from entering the exhaust under any sea conditions and at any angle of the vessel's use.

1. INSTALLATION

The following factors should be considered when planning the installation of your PAGURO generator:

1. Size and weight of the generator.
2. Size and weight of the inverter.
3. Generator location and mounting surface.
4. Inverter location and mounting surface.
5. Ventilation.
6. Exhaust system.
7. Fuel supply and return.
8. Raw water inlet and outlet (through exhaust system).
9. Oil fill and oil drain hose.
10. Electrical connections.
11. Maintenance and service accessibility.
12. Accessories.

Refer to the following illustration for the generator's overall dimensions.

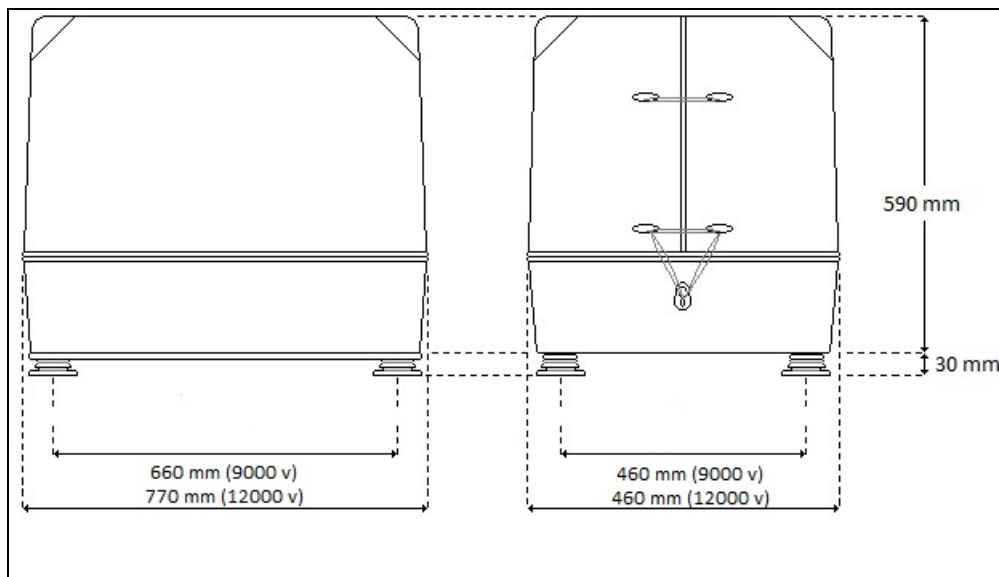

Generator dimensions

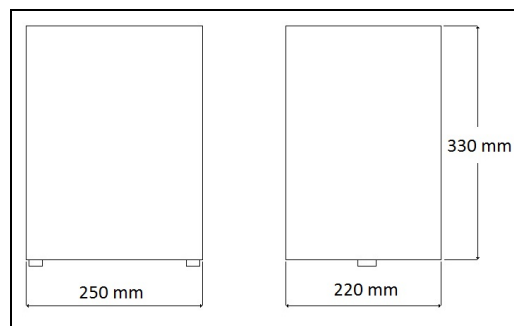

Inverter dimensions

EXTERNAL CONNECTIONS

The locations of the external connections are shown on the following illustration. The various lines should be of the specified gauges/diameters, not only to avoid loosening or leakage, but also because using the correct sizes will prevent unnecessary gaps in the sound-shield that could emit noise.

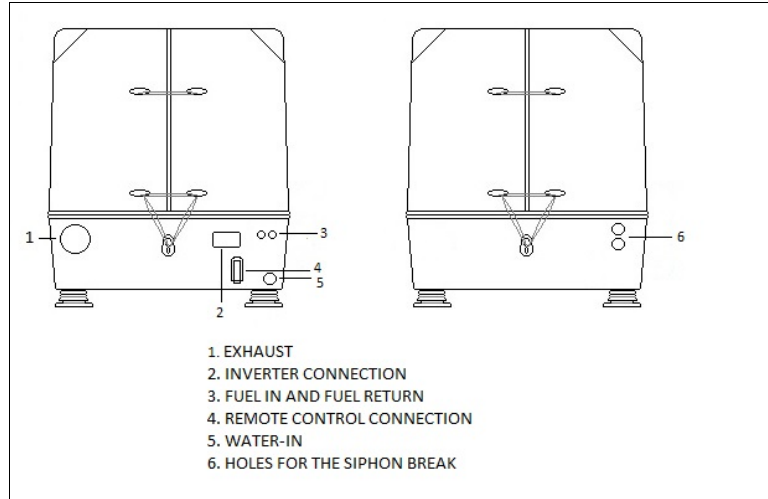

External connections

DIAMETERS:

PAGURO 9000 v

- ✓ Water inlet: 19 mm
- ✓ Exhaust system: 40 mm
- ✓ Fuel in: 8 mm
- ✓ Fuel return: 8 mm
- ✓ Siphon break: 19 mm
- ✓ Battery positive: 35 mm²
- ✓ Battery negative: 35 mm²
- ✓ Main out put voltage: 10 mm²

PAGURO 12000 v

- ✓ Water inlet: 19 mm
- ✓ Exhaust system: 45 mm
- ✓ Fuel in: 8 mm
- ✓ Fuel return: 8 mm
- ✓ Siphon break: 19 mm
- ✓ Battery positive: 35 mm²
- ✓ Battery negative: 35 mm²
- ✓ Main out put voltage: 10 mm²

VENTILATION

Allow for the sufficient intake of cool air for proper engine combustion and the discharge of the heated air while the generator is running. Since heated air rises, the intake of cool air should be directed into the lower area of the generator compartment and the heated air should be discharged from the upper area of the compartment. Minimum clearances of the generator's sound-shield hood from the generator compartment's bulkheads are shown in the illustration. These are the minimum clearances required to provide adequate ventilation.

NOTE: Engine combustion air enters the generator's enclosure through holes in the base of the enclosure. This area **must** be kept clear of obstructions to help insure air entry.

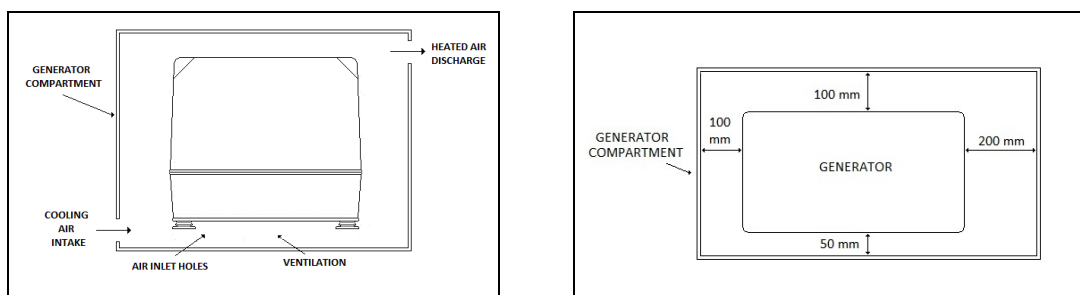

Minimum Clearance

LOCATION AND MOUNTING

A solid, level mounting platform is very important for the proper operation of your generator. Select a location that will allow adequate space on all sides for ventilation and servicing. Locate the generator away from living quarters and away from bilge splash and vapors.

The mounting platform may be of wood, metal or fiberglass. It must be horizontal and should be as small as possible to minimize vibrations. A low mounting platform is preferred because it will be stable and easy to build; a higher mounting platform must be very sturdy to avoid resonance and vibrations (see illustrations).

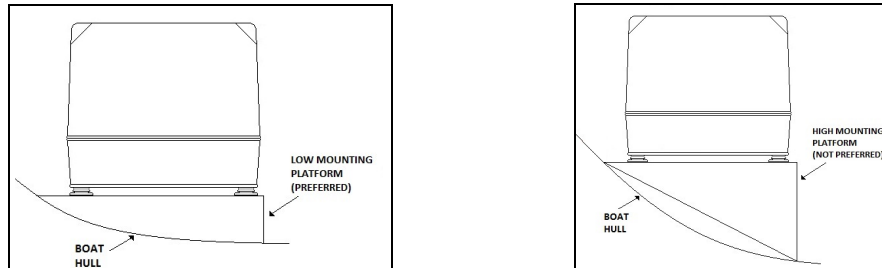

A further solution to increase the dampening of vibrations is adding a plate between the generator and the boat's mounting platform. This will also improve the sound insulation. For this plate not less than 30 mm thick wood and soft mounts. Position these mounts one on each corner (see illustration). Mount the plate to the boat's platform, then mount the generator to the plate.

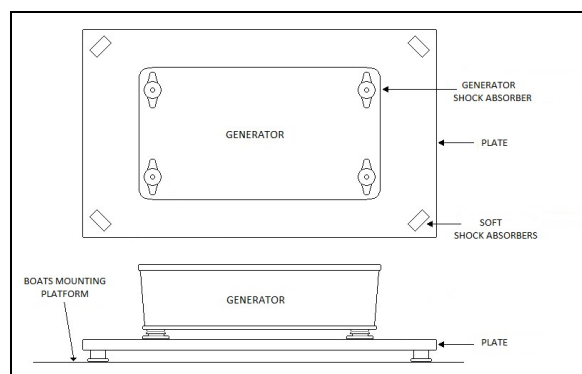

Generator mounting

FUEL LINES

Fuel supply line

In most installations, the generator would use the same fuel tank as the vessel's propulsion engine. If this is the case, the fuel supply line to the generator should come from its own pick-up in the common fuel tank and not tee off the supply line to the propulsion engine. To assure proper suction, the generator's fuel pump should not be more than 1 m above the bottom of the fuel pick-up tube.

Fuel return line

The fuel return line at the fuel tank should be extended down to the bottom of the tank in the same manner as the fuel pick-up tube. This **must** be done in an installation where the fuel tank is located below the engine's fuel system. This precaution insures against hard starting due to air displacing fuel siphoning out of the engine's fuel system through the return line when the generator is shut down.

NOTE: *The injection pump of the PAGURO is self-bleeding, it means that in case the engine shut-off for lack of fuel, after fuel tank filling up there is no need of disconnecting the pipes for bleeding, because this operation is simply obtained acting by hand on the lever of the feeding pump.*

NOTE: *Even if a fuel filter is contained in the capsule, it is necessary to install an external water/fuel separator.*

EXHAUST SYSTEM

It is important to install a proper exhaust system to avoid engine flooding. The system must be designed to prevent water from entering the exhaust line under any sea conditions and at any angle of the vessel's hull. Exhaust system failures are not covered by V.T.E.'s warranty. The installer should have a basic knowledge of marine installation requirements.

V.T.E. recommends installing an exhaust system having in-line mufflers (see illustration). The in-line water-lock mufflers **must**

be located below the generator. It must accumulate any water that runs back down the exhaust line after the engine is shut down. Designed the system, so there is an adequate drop in the line between the exhaust manifold and the through-hull discharge end of the line. The exhaust hose must be certified for marine use. Use the following illustrations as a general guide when installing an exhaust system.

! CAUTION:
An exhaust line that is too long and/or has a poor gradient can cause water to return back to the generator's engine when the generator is shut off!

! WARNING:
The exhaust system must be tight and free of leaks. Exhaust gasses are deadly. Display the Carbon Monoxide warning decal near your generator, on your cabin bulkhead, or in some other prominent location.

V.T.E. presumes that the installer of this marine diesel generator is familiar with the safeguards a water-cooled marine exhaust system will provide for the engine. Failure to design and layout a proper exhaust system can result in catastrophic damage to the diesel engine, and possibly result in the sinking of the vessel in which the unit is installed.

Standard system:

The best noise damping result is obtained fitting the 3 typical exhaust mufflers:

1. the first as water-lock avoids the risk of water return into the engine and dumps 50% of noise;
2. the second reduces a further 20% noise and must be fitted with a gradient towards the out let in order to avoid water return;
3. the third dumps a further 10% and avoids the risk of external seawater entrance due to waves.

Water-exhaust separator: it is possible to reduce the noise of the exhaust line installing a water-exhaust separator as per the following images. In this case, the exhaust gas output is separated from the water output, so that the typical splash of the water (of the traditional exhaust lines) is eliminated.

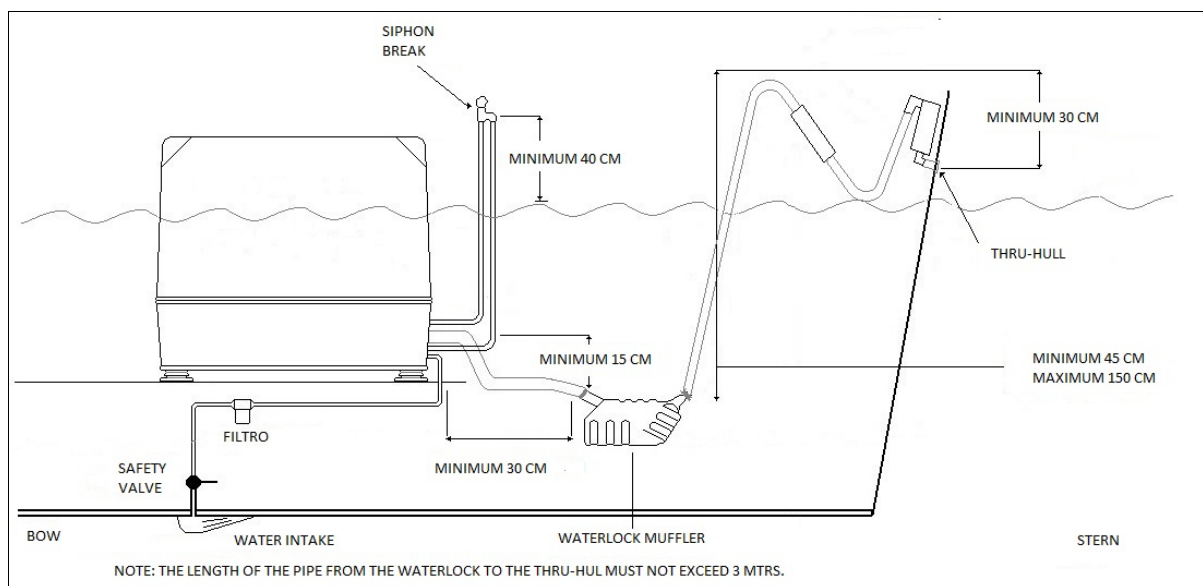

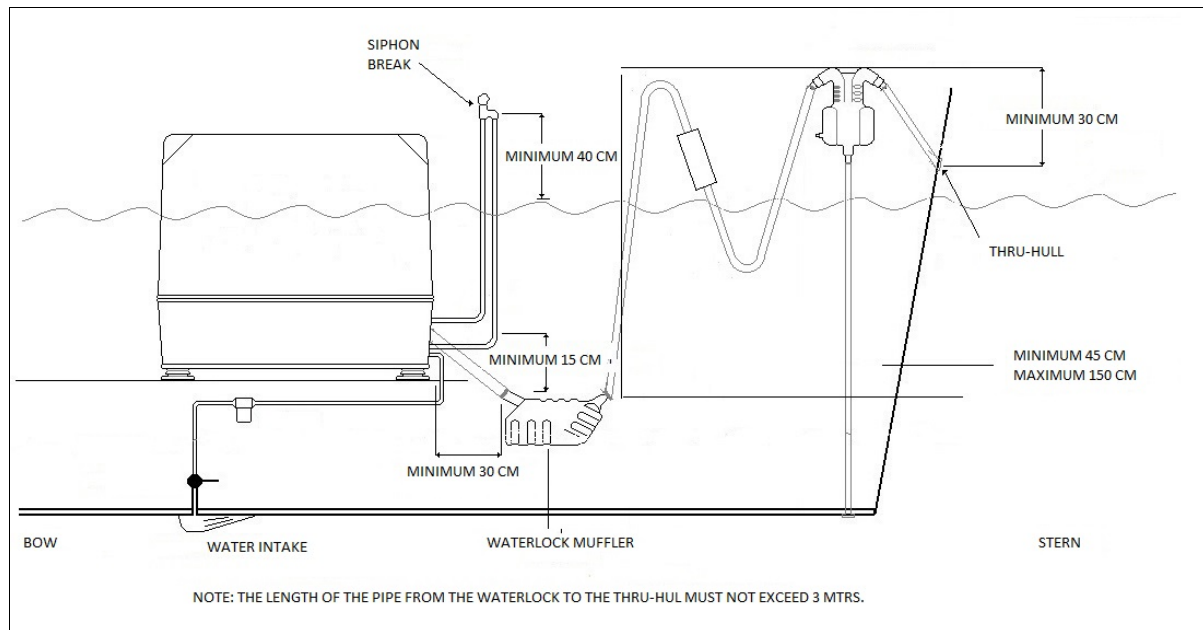

To avoid water returns, the water-lock muffler must be installed at a lower position than the generator, so that the connecting pipe from the generator to the water-lock muffler goes down. It is necessary that the water has a forced path in the down direction, so when the generator is stopped the water present in the cooling circuit flows to the muffler and not to the engine.

Please, also consider that the pipe from the generator to the water-lock muffler should be shorter as possible (but not less than 15 cm) in order to reduce the exhaust noise.

Please refer to the illustrations for the minimal/maximal length of the pipes and the location of the mufflers.

RAW WATER COOLING SYSTEM

Siphon-break

For installations where the external shock absorbers are close to or below the vessel's waterline, provisions must be made to install a siphon-break in the raw water supply hose to the exhaust elbow. The siphon-break provides an air vent in the raw water cooling system to prevent raw water from filling the exhaust system and the engine's cylinder when the engine is shut down.

▲ CAUTION:

Failure to use a siphon-break when the external shock absorbers are located at or below the waterline will result in raw water damage to the engine and possible flooding of the boat.

If you have any doubt about the position of the external shock absorbers relative to the vessel's various operating conditions or when the vessel is not under way, ***install a siphon break***. This precaution is necessary to protect your engine.

The siphon-break must be installed in the high point of a hose that is looped a minimum of 50 cm above the vessel's waterline. This siphon-break must always be above the waterline during all angles of vessel operation to prevent siphoning from occurring. V.T.E. has provided two siphon-break hoses (these are tagged). The hose (19 mm diameter) to the siphon-break connects to the raw water line at the raw water pump outlet. The hose (19 mm diameter) from the siphon-break attaches to the oil cooler inlet. If not ordered and included in the generator supply, the owner must furnish the siphon-break, and any additional lengths of hose that may be required.

NOTE: *A siphon-break requires periodic inspections and cleaning to ensure proper operation. Failure to properly maintain a siphon-break can result in severe engine damage. Consult the siphon-break manufacturer for a proper maintenance schedule.*

Raw water intake

A flush-type thru-hull fitting is recommended for the raw water intake. It should be located on the boat's hull where it will be below the waterline during all angles of the boat's operation.

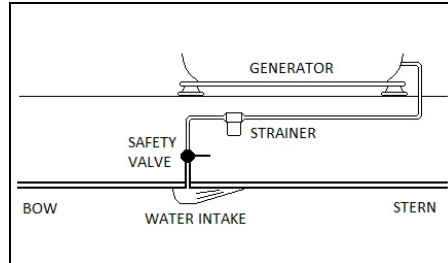

NOTE: *the sea water intake is usually designed asymmetrically, so that depending from the fitting direction can cause, when the boat is sailing, pressure or vacuum in the water circuit connected. For a generator the water intake must be fitted into the direction causing vacuum, because on the contrary a self water entrance can be caused when the boat is sailing and the generator is not running, flooding the exhaust line with water that finally reaches the engine oil sump causing severe damages to the engine.*

INVERTER INSTALLATION

The generator is supplied with an external inverter that must be connected to the generator. The inverter is supplied with 2 cables of 2 mt length each: one has 6 wires and it has a male connector; one has 4 free wires.

Connect the male connector of the 6 wires cable to the female connector present on the capsule (refer to the picture "External connections" page 12).

Connect the 4 wires cable to the gray box located inside the capsule (pass the cable through the hole present close to the fuel-in and fuel-return holes). The 4 wires cable must pass through the hole present in the bottom of the grey box, then: connect the gray wire to the white present on the terminal boards, the black wire to the black, the brown wire to the brown. Connect the yellow/green wire to the negative stud inside the grey box.

Please refer to the electrical scheme of this manual.

STARTING BATTERY CONNECTION

The PAGURO generator is negative grounded. For electric starting install a 12V battery of 90Ah. Connect the positive (+) battery cable to the starter solenoid where is already fitted a thin red cable and the negative (-) cable to the engine ground stud (one of the 2 studs located on the starter where is already foreseen a metallic loop)

Please refer to the electrical scheme of this manual.

The generator's battery charger will charge its starting battery only (8A max)

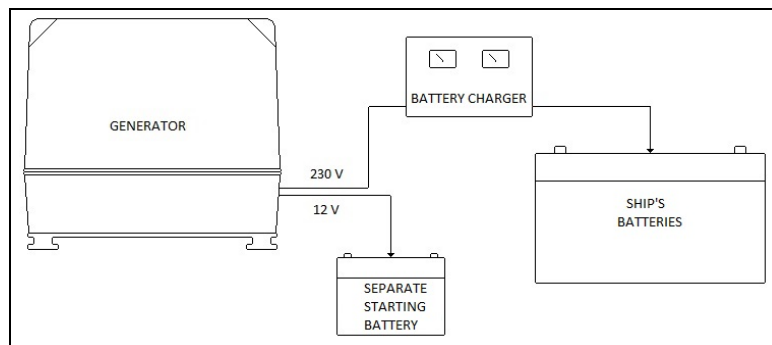

STARTING BATTERY

MAIN OUTPUT VOLTAGE (230 V AC)

The connection of the 230 V AC is located into the inverter box.

Open the inverter box and connect the 230 V cable from the transfer switch present on board (generator/shore line) to the terminal boards located inside: consider that the external terminals are the 230 V AC and the central one is the ground.

The diameters of the cable must be not less of 10 mm²

Please refer to the electrical scheme of this manual.

As the most of the boats have installed 230 V (115 V) feeding line from the shore, it has to be absolutely avoided that the shore line and the generator remain contemporaneously connected to the boat plant.

A manual switch (shore / generator) or an automatic switch (shore / generator) must be provided.

Both the lines or at least the generator line only, have to be protected with a thermo-switch, fitted on the main board panel. For your **PAGURO** choose a:

	230V 50cyc.
PAGURO 9000 v	35A
PAGURO 12000 v	44A

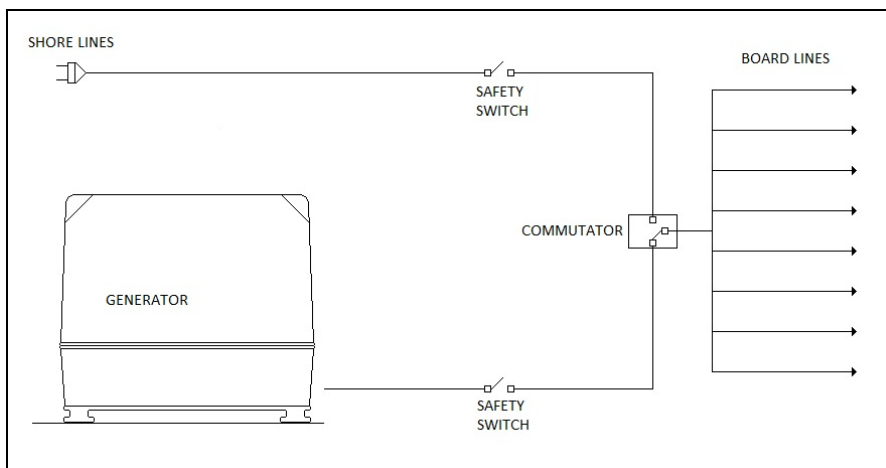

CONTROL PANEL

Mount the plug-in control panel in any desired remote location. The panel is furnished with 15 m of cable. When installing, pass the cable through bulkheads by disconnecting the cable at the control panel side. Refer to the following drawing for control panel dimensions.

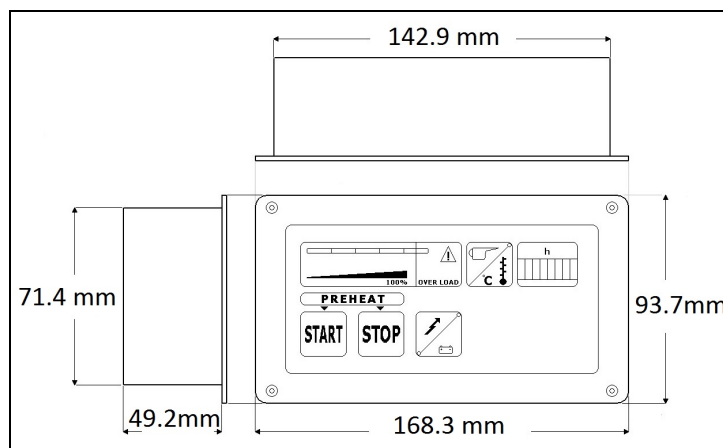

Control panel dimensions

2. PREPARATION FOR INITIAL START-UP

DIESEL FUEL

The generator is fed by diesel through the two fuel connections (fuel-in and fuel-return). Do not use kerosene or home heating fuel.

Care of the Fuel Supply

Use only clean diesel fuel. The clearance of the components in your injection pump is very critical; invisible dirt particles which might pass through the filter can damage these finely finished parts. It is important to buy clean fuel, and keep it clean. The best fuel can become unsatisfactory by careless handling or improper storage facilities. To assure that the fuel going into the tank for your engine's daily use is clean and pure, purchase a well-known brand of fuel. Also install and regularly service a good fuel / water separator filter between the fuel tank and the generator.

ENGINE OIL SPECIFICATION

Use a heavy duty engine oil; the engine manufacturer prescribes SAE 15W 40. Change the engine oil after an initial 50 hours of break-in operation, and every 100 hours of operation thereafter. For recommended oil viscosity, see the following chart:

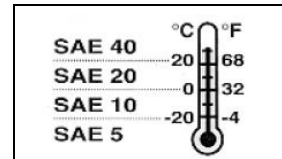

Please refer to the engine manufacturer manual for any information.

⚠ CAUTION:

Do not allow two or more brands of engine oil to mix. Each brand contains its own additives; additives of different brands could react in the mixture to produce properties harmful to your engine.

PRE-START INSPECTION

Before starting your engine for the first time, or after a prolonged layoff, check the following items:

Check the engine oil level. Add oil to maintain the level at the high mark on the dipstick.

Turn on the fuel supply, then check the fuel supply and examine the fuel filter / water separator bowl for contaminants.

NOTE: refer to the specifications for the proper diesel fuel and lubricating oil types and quantities.

- Check the DC electrical system. Inspect wire connections and battery cable connections. Make certain the positive (+) battery cable is connected to the starter solenoid and the negative (-) cable is connected to the engine ground stud.
- The shore power safety switch must be OFF.
- The shore power transfer switch must be in the GENERATOR mode.
- Open the raw water intake.
- Visually examine the generator. Look for loose or missing parts, disconnected wires, and unattached hoses. Check the threaded connections. Check for fuel leaks.
- Make sure the exhaust system is secure and all the connections are tight.
- Make sure there is a good ventilation and an ample air supply. These are necessary for proper engine performance.
- Make sure the mounting installation is secure.
- Check load leads for correct connections as specified in the wiring diagrams.
- Be sure no other generators or utility power is connected to the load lines.

⚠ CAUTION:

When starting the generator, it is recommended that all AC loads, especially large motors, be switched off until the engine has come up to speed and, in cold climates, starts to warm up. This precaution will prevent damage caused by unanticipated operation of the AC machinery will prevent a cold engine from stalling.

3. STARTING/STOPPING PROCEDURE

⚠ CAUTION: *All AC loads must be switched off before starting. This precaution will prevent damage caused by unanticipated operation of AC machinery and will prevent a cold engine from stalling.*

PREHEATING

This generator has a 12VDC electric starter.

To preheat push contemporaneously the START and STOP and keep pushed for 10 seconds. The green led on the remote control panel will be lighted.

STARTING OPERATION

Release the STOP button and keep the START button pushed, the yellow start indicator light will come on and start to blink. Once the engine fires and runs, the yellow start indicator light will go out and the green run indicator light will come on.

NOTE: *If a start attempt is aborted, the yellow indicator light will continue to blink. To reset the circuit, press the STOP button.*

Apply a light load to the generator and allow the engine to warm up to operating temperature before applying heavy loads.

NOTE: *Some unstable running may occur in a cold engine. This condition should smooth out as the engine warms up and when the generators loads are applied.*

OPERATING THE GENERATOR

After the generator has started, run it with a medium load for warm up. If possible, apply the load in stages.

⚠ CAUTION:
Never operate the engine for long periods of time without an amperage load being applied, otherwise carbon build-up may occur which can cause severe damage to the engine.

INITIAL START-UP CHECK LIST

- ✓ Check for possible leaks from all the connections inside the sound-shield.
- ✓ Make sure the cooling water is discharging properly, outboard from the exhaust outlet.
- ✓ Make certain that the generator is mounted securely.
- ✓ Listen for unusual sounds and vibrations.

STOPPING THE GENERATOR

Remove the AC loads from the generator one at a time and allow the generator to run for an additional 3 to 5 minutes (this stabilizes its operating temperature).

To stop the generator, press the STOP button on the control panel; shutdown is automatic.

Check the lube oil level a few minutes after stopping the engine, because lube oil from the bearings etc. continues to drain down into the oil sump. Disregarding this fact and not maintaining the proper oil level may lead to overfilling, causing overheating and the possibility of engine runaway.

After shutdown, carefully inspect the generator. Check for possible leaks from all the connections inside the sound-shield.

4. BREAK-IN PROCEDURE/ DAILY PROCEDURE

After the generator has been started, check for proper operation and then encourage a fast warm-up. Run the generator between 20% to 60% of full load for the first 10 hours.

⚠ CAUTION:
Do not attempt to break-in your generator by running without a load.

After the first 10 hours of the generator's operation, the load can be increased to the full-load rated output; then periodically vary the load.

Avoid overload at all times. An overload is signaled by the red LIGHT lighting located on the remote control panel, by a smoky exhaust with reduced output voltage and frequency. Monitor the current being drawn from the generator and keep it within the generator's rating.

To protect against unintentional overloading of the generator, the generator's output leads should be routed through a circuit breaker that is rated at the rated output of the generator.

Note: *be aware of motor starting loads and the high current drawn required for starting motors. This starting amperage drawn is 3 times normal running amperage. See GENERATOR INFORMATION in this manual.*

CHECK LIST

Follow this check list each day before starting your generator.

- ✓ Record the hour-meter reading in your log (engine hours relate to the maintenance schedule).
- ✓ Visually inspect the engine for fuel, oil or water leaks.
- ✓ Check the oil level (dipstick).
- ✓ Check your diesel fuel supply.
- ✓ Check the starting batteries (weekly).
- ✓ Check for abnormal noise such a knocking, vibration and blow by sounds.
- ✓ Confirm exhaust smoke:
 - When the engine is cold - White Smoke.
 - When the engine is warm - almost Smokeless
 - When the engine is overloaded - some Black Smoke
- ✓ Make sure the cooling water is discharging properly, outboard from the exhaust outlet.

NOTE: *After the first 20 hours of generator operation, check the maintenance schedule for the first 20 hours service check.*

⚠ CAUTION:
Do not operate the generator for long periods of time without a load being placed on the generator.

STOPPING THE GENERATOR

Remove the AC loads from the generator one at a time and allow the generator to run for an additional 3 to 5 minutes (this stabilizes its operating temperature).

To stop the generator, press the STOP button on the control panel; shutdown is automatic.

Check the lube oil level a few minutes after stopping the engine, because lube oil from the bearings etc. continues to drain down into the oil sump. Disregarding this fact and not maintaining the proper oil level may lead to overfilling, causing overheating and the possibility of engine runaway.

After shutdown, carefully inspect the generator. Check for possible leaks from all the connections inside the sound-shield.

5. MAINTENANCE SCHEDULE

In order to use this Maintenance Schedule, it will be necessary to log your engine hours. Use your engine hour-meter or record your engine hours by running time.

NOTE: *Many of the following maintenance procedures are simple but others are more difficult and may require the expert knowledge of a service mechanic.*

⚠ WARNING:

Never attempt to perform any service while the generator is running. Wear the proper safety equipment such as goggles and gloves, and use the correct tools for each job. Disconnect the battery terminals when servicing any of the engine's DC electrical equipment.

OIL LEVEL CHECK – DAILY OR EVERY 10 WORKING HOURS

Remove the dipstick- if the level is under the minimum, fill up.

COOLANT LEVEL CHECK – DAILY OR EVERY 10 H

Carry out this operation while the engine is still cold; remove heat exchange plug; if level is below reference mark, fill up and put the cap on.

FUEL LINES – DAILY OR EVERY 10 H

Check the fuel lines; check there are no leakages.

WATER/FUEL SEPARATOR – DAILY OR EVERY 10 H

Check there is no water and dirt in the fuel; drain or replace the filter if necessary.

VISUAL INSPECTIONS - DAILY OR EVERY 10 H

Visually inspect the engine for fuel, oil or water leaks.

BATTERY CHECK – WEEKLY

Check the batteries status and make sure the connections are very tight; clean off excessive corrosion.

CLEANING THE GENERATOR – WEEKLY

Keep the generator's surface clean. Surface dirt and oil will inhibit the generator's ability to remain cool.

EXHAUST SYSTEM – AFTER THE FIRST 50 H AND WEEKLY

Inspect for leaks. Check the anti-siphon valve operation. Check that all connections are tight. Check the exhaust elbow for carbon and/or corrosion buildup on inside passages; clean and replace as necessary.

Warning: a defective exhaust elbow can cause carbon monoxide leakage!

HARDWARE FASTENINGS AND ELECTRICAL CONNECTIONS – AFTER THE FIRST 50 H- EVERY 100 H

Inspect and tighten all fastenings and accessible screws, bolts and nuts. Inspect all wiring and electrical connections.

ENGINE OIL REPLACEMENT – AFTER THE FIRST 50 H – EVERY 125 H

Draw oil out via the special pump; remove oil filler cap; pour the oil in and reassemble oil cap; make sure the level is nearly at max; take the burnt oil to the appropriate collection site.

CHECK COOLING CIRCUIT SLEEVES – WEEKLY OR EVERY 250 H

Squeeze sleeves to check for wear; replace them if worn out (loosen sleeves fixing bands, remove and throw sleeve away, replace with original sleeve, fit sleeves and clamps back in place).

OIL FILTER REPLACEMENT – EVERY 250 H

Remove the filter and take it to the appropriate collection site; replace with original filter type.

FUEL FILTER REPLACEMENT – EVERY 250 H

Remove the filter and take it to the appropriate collection site; replace with original filter type; loosen the filter support screw and breathe.

ZINC ANODES CHECK – EVERY 250 H

Loosen plug, on the heat exchanger, away if worn out; throw plug away if worn out; replace with original plug; put plug back.

SEA WATER PUMP CHECK – EVERY 250 H

Check the sea-water pump impeller; remove screws and pump cover; take the impeller out; throw impeller away if worn out; replace with an original impeller; reassemble the impeller; reassemble gasket, cap and screws. Check and clean the Y bronze filter, located nearby the sea-water pump.

STARTER MOTOR – EVERY 250 H

Check the solenoid and motor for corrosion. Remove and lubricate. Clean and lubricate the starter motor pinion drive.

HEAT EXCHANGER TUBE NEST CLEANING AND COOLANT REPLACEMENT – EVERY 500 H.

Drain exchanger cooling liquid; shut heat exchanger outlet; remove plug from the engine; drain coolant from engine; put cap back on engine; remove outlet fastening nuts; loosen sleeve fixing bands; remove the exhaust manifold; loosen the screws which fasten the front cover; remove cap and O.R. ; loosen thermostatic valve fastening screws; take the thermostatic valve body out; loosen cap fastening screws; remove cap and O.R.; take tube nest out; dip tube nest into a solution of : water 50°C (90%) and hydrochloric acid (10%) - use gloves and goggles; remove it when effervescence is off; rinse in water. If worn out, replace o-rings, outlet seals and thermostatic valve seals. Put tube nest back and O.R.; reassemble O-ring, cap and tighten screws; fit circlip and flange back in place; reassemble O-ring and cap; reassemble thermostatic valve body; tighten thermostatic valve fastening screws; reassemble O-ring and exhaust manifold; tighten exhaust pipe fastening nuts; tighten hose clamps for sea water inlet and outlet; remove cap and pour liquid into heat exchanger; level should always be approximately 2 cm below filling hole; put heat exchanger plug back.

PRESCRIBED COOLANT: 50% TOTAL ANTIFREEZE, 50% water.

SETTING ROCKER ARMS CLEARANCE – EVERY 500 H

This operation must be performed by authorized personnel trained on the product.

SETTING AND INJECTORS CLEANING – EVERY 1000 H

This operation must be performed by authorized personnel trained on the product.

PARTIAL OVERHAUL – EVERY 2500 H

This operation must be performed by authorized personnel trained on the product.

TOTAL OVERHAUL – EVERY 5000 H

This operation must be performed by authorized personnel trained on the product.

6. EXHAUST SYSTEM

EXHAUST SYSTEM PRECAUTIONS

Carbon Monoxide

The best protection against carbon monoxide poisoning is a daily inspection of the complete exhaust system. Check for leaks around manifolds, gaskets and welds. Make sure exhaust lines are not heating surrounding areas excessively. If excessive heat is present, correct the situation immediately. If you notice a change in the sound or appearance of the exhaust system, shut down the unit immediately and have the system inspect and repaired at once by a qualified mechanic.

⚠ WARNING: Exhaust gasses contain Carbon Monoxide, an odorless and colorless gas.

Carbon Monoxide is poisonous and can cause unconsciousness and death.

Symptoms of Carbon Monoxide exposure can include:

- Dizziness;
- Nausea
- Headache;
- Vomiting;
- Throbbing in Temples;
- Muscular Twitching;
- Weakness and Sleepiness;
- Inability to Think Coherently.

IF YOU OR ANYONE ELSE EXPERIENCE ANY OF THESE SYMPTOMS GET OUT INTO THE FRESH AIR IMMEDIATELY. If symptoms persist, seek medical attention. Shut down the unit and do not restart unit until it has been inspected and repaired.

Insulation

Inspect insulated portions of the exhaust system to ensure there is no deterioration of the insulation.

Overcranking

⚠ CAUTION: prolonged cranking intervals without the engine starting can result in the engine exhaust system filling with raw water. This may happen because the pump is pumping raw water through the raw water cooling system during cranking. This raw water can enter the engine's cylinder once the exhaust system fills. Prevent this from happening by closing the raw supply through-hull shutoff, draining the exhaust muffler, and correcting the cause of the excessive engine cranking. Remember that engine damage resulting from raw water entry is not covered by V.T.E. S.r.l.'s warranty.

7. COOLING SYSTEM

RAW WATER COOLING SYSTEM

The raw water flow is created by a positive displacement impeller pump that is gear-driven by the camshaft. This pump draws cooling water directly from the raw water source (ocean, lake or river) through a hose.

The raw water is pumped to the oil cooler in the sump. The water flows from the oil cooler to the heat exchanger. From the heat exchanger discharges into the water-injected exhaust manifold where it mixes with and cools the exhaust gasses.

COOLANT TEMPERATURE SWITCH

The coolant temperature switch is located near the thermostat housing (see illustration). If the coolant's operating temperature reaches approximately 99°C this switch will light up the red (LED) engine overheat indicator on the control panel and shut down the generator.

RAW WATER PUMP

The raw water pump is a self-priming, rotary pump with a non-ferrous housing and a neoprene impeller. The impeller has flexible vanes which wipe against a curved cam plate within the impeller housing, producing the pumping action. On no account should this pump be run dry as water acts as a lubricant for the impeller. There should always be a spare impeller and impeller cover gasket (an impeller kit) onboard. Raw water pump impeller failures occur when lubricant (raw water) is not present during engine operation. Such failures are not warrantable and operators are cautioned to make sure raw water flow is present at start-up. The neoprene impeller has a limited lifetime and must be inspected regularly.

NOTE: *should a failure occur with the pump's internal parts (seals and bearings), it may be more cost effective to purchase a new pump and rebuild the original pump as a spare.*

Inspecting / Changing the Raw Water Pump Impeller

Close the raw water intake valve. Remove the pump cover and, with the aid of two small screw-driver, carefully pry the impeller out of the pump. Install the new impeller and gasket. Move the blades to conform to the curved cam plate and push the impeller into the pump's housing. When assembly, apply a thin coating of lubricant to the impeller and gasket. Open the raw water intake valve.

NOTE: *never allow the pump to run dry. Even a short period of dry running may destroy the impeller.*

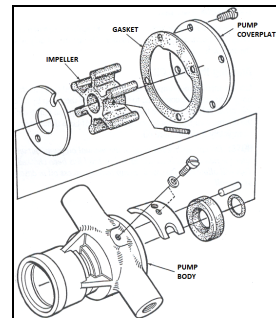

RAW WATER INTAKE STRAINER

NOTE: *always install the strainer at or below the waterline so the strainer will always be self-priming.*

A clean raw water intake strainer is a vital component of the engine's cooling system. Include a visual inspection of this strainer when making your periodic engine check. The water in the glass should be clear.

Perform the following maintenance after every 100 hours of operation:

1. Close the raw water seacock.
2. Remove and clean the strainer filter.
3. Clean the glass.
4. Replace the sealing washer if necessary.
5. Reassemble and install the strainer.
6. Open the seacock.
7. Run the engine and check for leaks.

NOTE: *also follow the above procedure after having run hard aground.*

If the engine temperature gauge ever shows higher than normal reading, the cause may be that silt, leaves or grass may have been caught up in the strainer, slowing the flow of raw water through the cooling system.

8. LUBRICATION SYSTEM

ENGINE OIL

Use a heavy duty engine oil; the engine manufacturer prescribes SAE 15W 40. Change the engine oil after an initial 50 hours of break-in operation, and every 125 hours of operation thereafter. For recommended oil viscosity, see the following chart:

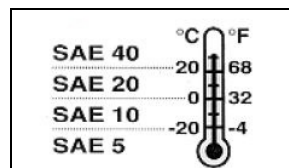

Please refer to the engine manufacturer manual for any information

⚠ CAUTION: *do not allow two or more brands of engine oil to mix. Each brand contains its own additives; additives of different brands could react in the mixture to produce properties harmful to your engine.*

OIL PRESSURE

There is a low-oil pressure automatic emergency shutdown indicator on the control panel (red light). If this alarm lids, inspect the reasons. Please refer to the engine manufacturer manual for the action to be done in this case.

OIL COOLER

The engine oil is cooled by a plate-type oil cooler that is located close to the oil sump. The oil cooler is connected to the engine's raw water cooling system and does not require maintenance.

OIL FILTER

There is an oil filter fitted on the engine. Please refer to the engine manufacturer manual

CHECKING THE OIL

Check the lube oil level daily, prior to starting. With continuous operation, check the oil level every 8-10 hours.

Check the lube oil level a few minutes after stopping the engine because lube oil from the bearings etc. continues to drain down into the oil sump. Disregarding this fact and not maintaining the proper oil level may lead to overfilling, overheating and engine runaway.

If a top-up is necessary, clean the area around the oil filler to prevent dirt from entering the engine.

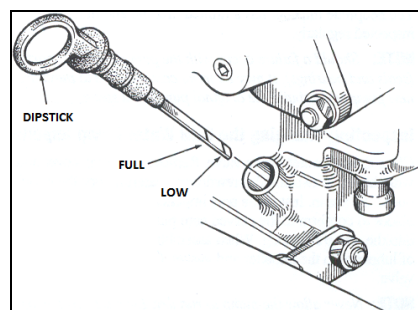

CHANGING THE OIL

Please refer to the engine manufacturer manual. Change the oil only when the engine is warm.

DRAINING THE USED OIL

Use the manual oil pump-out empty the used oil. This pump is connected to the bottom of the sump by a flexible hose. Remove the plug on the pump and pump out the oil into a suitable container; use a piece of hose if necessary. Completely drain the used oil.

NOTE: *do not replace the plug on the manual oil pump-out until after the new oil has been added and its level has been checked. This will allow the operator to pump out any excess oil in case of overfill.*

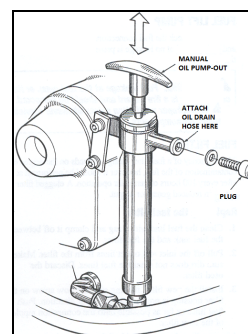

Always observe the used oil as it is removed. A yellow/brown emulsion colour indicates the presence of water in the oil. Although this condition is rare, it does require prompt attention to prevent serious damage. Call a qualified mechanic should water be present in the oil. Raw water present in the oil can be the result of a fault in the exhaust system attached to the engine and/or a siphoning of raw water through the raw water cooling circuit into the exhaust, filling the engine. This problem is often caused by the absence of an anti-siphon valve, its poor location or lack of maintenance.

▲ CAUTION:

used engine oil contains harmful contaminants. Avoid prolonged skin contact. Clean skin and nails thoroughly using soap and water. Launder or discard clothing or rags containing used oil. Discard used oil properly.

ADDING NEW OIL

Add new oil through the oil filler.

After refilling with new oil, run the engine for a few moments. Make sure there is no leakage around the manual oil pump, then stop the engine. Then check the quantity of oil with the lube oil dipstick. Fill to, but not over the full mark on the dipstick, should the engine require additional oil.

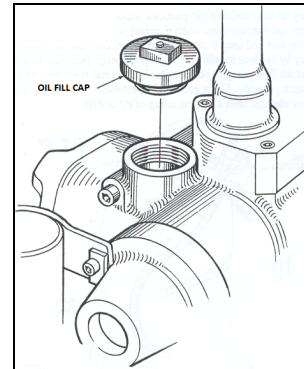

9. FUEL SYSTEM

DIESEL FUEL

Please refer to the engine manufacturer manual for any information.

FUEL ADDITIVES

If fungus or bacteria is causing fuel problems, you should have an authorized dealer correct these problems. Then use a diesel fuel biocide to sterilize the fuel (follow the manufacturer's instruction).

CARE OF THE FUEL SUPPLY

Use only clean diesel fuel! Purchase a well-known brand of fuel. The clearance of the components in your fuel injection pump is very critical; invisible dirt particles which might pass through the filter can damage these finely finished parts. It is important to buy clean fuel and keep it clean. The best fuel can become unsatisfactory by careless handling or improper storage facilities. To assure that the fuel going to your engine is clean and pure, be sure to filter it properly. Use a good fuel/water separator having a filter element.

FUEL LIFT PUMP

Periodically check the fuel connections to and out of the pump and make sure that no leakage is present and that the fittings are tight and secure.

- WARNING:

fuel leakage at the fuel pump or its connections is a fire hazard and should be corrected. Make sure proper ventilation exist whenever servicing fuel system components.

FUEL FILTER

The frequency of a fuel filter change depends on the degree of contamination of the fuel, however it should be performed according the engine manufacturer manual.

REPLACING THE FUEL FILTER

Clean the fuel line with a rag and clamp it off between the fuel tank and the fuel filter.

Pull off the inlet and outlet lines from the filter. Make sure dirt does not enter the fuel lines. Discard the used filter.

Install the new filter, making sure the flow arrow on the filter housing is pointed in the proper direction. Push the fuel lines as far as possible onto the connection nipples of the new filter.

After installing the new filter, bleed the air from the fuel lines using the manual fuel primer

FUEL SUPPLY LINE

Refer to FUEL LINES in the INSTALLATION section of this manual for information about the fuel supply.

▲ WARNING:

shut off the fuel valve at the tank when servicing the fuel system. Take care in catching any fuel that may spill. DO NOT allow any smoking, open flames or other sources of fire near the fuel system when servicing. Ensure proper ventilation exist when servicing the fuel system.

FUEL FILTER OF THE WATER-SEPARATING TYPE

We recommends that you install and regularly service a good quality R.I.Na. approved visual-type primary fuel filter of the water-separating type. This fuel filter/water separator must be installed between the fuel tank and the engine to prevent any contaminants or water that may be in the fuel from reaching the fuel lift pump and causing damage to the fuel system components. It may also prolong the life of the fuel filter that comes installed on the fuel line. It is the responsibility of the owner/operator to install this fuel filter/water separator. It must be located outside the sound-shield.

Most installers include a fuel filter/water separator with the installation package as they aware of the problems contaminants in the fuel can cause.

Keep in mind that if a water separator type filter is not installed between the fuel supply tank and the engine-mounted fuel system, any water in the fuel will affect fuel pump, engine filter and injection equipment. The owner/operator is responsible for making certain the fuel reaching the engine's injection equipment is free of impurities. This process is accomplished by installing and maintaining a proper fuel filter/water separator.

FUEL INJECTION PUMPS

The fuel injection pumps are very important component of the diesel engine, requiring the utmost care in handling. The fuel injection pumps have been thoroughly bench-tested and the owner-operator is cautioned not to attempt to service them. If it requires servicing refer to an authorized fuel injection pump service facility. Do not attempt to disassemble and repair them.

FUEL SHUT OFF SOLENOID

The fuel shut off solenoid is deactivated when the STOP button on the control panel is pushed. This will stop the fuel flow and shut down the engine; the fuel solenoid indicator on the control panel will go out. This shut off solenoid is factory-set and will not require adjustment. The fuel shutoff solenoid has a small lever that must be always in the up direction. **In the low position, the solenoid valve remains always open, so it is not electrically connected, and, in case of failure due to overheating and/or low oil pressure, the remote control panel cannot stop the engine.**

BLEEDING THE FUEL SYSTEM

The fuel circuit is self-bleeding; any air in the fuel lines will bleed out through the fuel return line. Bleeding can also be done by using the manual fuel primer on the fuel lift pump. In case the generator is shut down due to lack of fuel, use the manual fuel primer to bleed the system after refilling the fuel tank; it will not be necessary to disconnect the fuel lines to bleed the air. Also use the manual fuel primer to bleed the system after changing the fuel filters.

Bleeding the fuel system will also be necessary before the generator is laved-up during the off-season or for prolonged periods of inactivity.

To use the manual fuel primer, work the lever down.

SPARE PARTS

While the likelihood of having to service the system at sea is slim, the possibility does exist. Therefore, we recommend that banjo washers, injector seat washers and a fuel filter be carried on board at all times. Purchase needed spare parts from your

local Volpi Tecno Energia dealer or distributor. If a leak should develop at a banjo washer that cannot be corrected by a simple tightening of the fitting, replace the sealing washer with a replacement found in the hardware kit for your model.

10. ENGINE TROUBLESHOOTING

THE ENGINE DOES NOT START

- Valves closed;
- Pipes clogged;
- Fuel filter clogged;
- Air in the fuel system;
- Tank bleeding hole clogged;
- Injector stuck;
- Faulty fuel pump;
- Low battery;
- Faulty electrical connections;
- Faulty START button on the remote control panel;
- Faulty starting motor.

THE ENGINE STARTS AND STOPS

- Air filter clogged;
- Fuel filter clogged;
- Air in the fuel system;
- Tank bleeding hole clogged;
- Faulty fuel pump;

BLACK SMOKE

- Air filter clogged.

WHITE SMOKE

- Break-in incomplete;
- Segmenti
- Cylinder worn

LOW OIL PRESSURE

- Bronzine banco-biella usurate
- Pressure regulator valve stuck;
- Regulator valve not adjusted;
- Oil pump worn;
- Air in the oil suction;
- Faulty pressure switch.

COOLANT HIGH TEMPERATURE

- Engine water pump worn;
- Faulty thermostat;
- Dirty tube nest;
- Sea-water pump impeller worn;
- Pipes clogged;
- Air suction in the hose between the water intake and the sea-water pump.
-

11. DC ELECTRICAL SYSTEM

CONTROL PANEL

This plug-in remote control panel provides the operator with all the necessary information and controls to use the generator. The panel has START and STOP buttons, and LED proportional load indicator, a coolant/oil pressure warning light, a low battery warning light, a fuel shut off solenoid light, and an hour-meter.

The load indicator is designed to avoid an excessive current draw from the generator due to many loads having been applied at the same time. The indicator will begin to show the load after the first half of the required current is supplied, and it will indicate that an acceptable load is being provided up to the point where all the LED's except the last one are lit (5 green LED's are lit). If the last LED (red) becomes lit, it indicates an overload. The load that caused this red LED to light up must be switched off to return the indicator to a normal position.

The oil pressure / coolant temperature warning light (red) lights up when either the oil pressure is too low or the engine is overheated. The engine will shut down if it overheats or there is an oil pressure failure.

The fuel shutoff solenoid light (yellow) blinks when the START button is pushed and goes off after the engine starts. If it continues to blink and the engine doesn't start, it means the starting battery is too low.

The engine/generator "ON" light (green) will be lit during normal operation.

If the engine is not running and the shutoff solenoid is energized (yellow LED is blinking), the starting battery is supplying unneeded power to the engine. Reset by pushing the STOP button.

If the YELLOW LED remains flashing when the set is running normally, it means that the internal battery charger protection has tripped, so the starting battery is no longer connected to it. In that condition the automatic protection shut-off system is not operative, **so do not operate the set with the YELLOW light flashing.**

Reset the device by pushing the button located on the side of the GREY box fitted on the set. The set can normally operate when the YELLOW flashing LED is OFF and the GREEN on the opposite corner is ON.

if the START button is pushed by mistake while the engine is running, an electrical safety protects the starter motor by preventing its solenoid from energizing.

For passing through small holes the remote control panel cable, the disconnection must be made panel side, opening the back cover, and not plug side, that is welded.

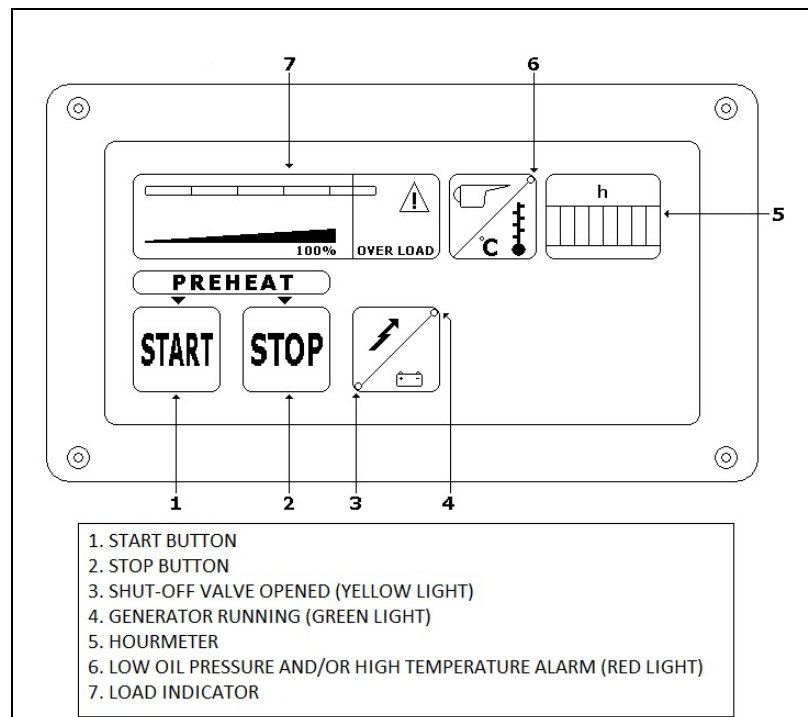

12 VOLT DC CONTROL CIRCUIT

The engine has a 12V DC electrical circuit that is shown on the wiring diagrams. Refer to these diagrams when troubleshooting or when servicing the DC electrical system.

▲ CAUTION:
to avoid damage to the battery charging circuit, never shut off the engine battery switch while the engine is running. Shutoff the engine battery switch, however, to avoid electrical shorts when working on the engine's electrical circuit.

▲ WARNING:
do not remove the control box cover when the generator is running. Dangerous high voltage is present at this location.

BATTERY

The minimum recommended capacity of the battery used in the engine's 12V DC control circuit is 90 Ah.

Battery Care

Review the manufacturer's recommendations and then establish a systematic maintenance schedule for your generator's starting batteries and house batteries.

- Monitor your voltmeter for proper charging during engine operation;
- Make certain that battery cable connections are clean and tight to the battery posts (and to your generator);
- Keep your batteries clean and free of corrosion.

▲ WARNING: *sulfuric acid in lead batteries can cause severe burns on skin and damage clothing. Wear protective gear.*

Checking the service battery

Check the voltage of the service battery. This battery should have a voltage between 13 and 14 volts when the engine is running. If not, there is a problem in the service battery charging circuit by checking the wiring and connections, the solenoid, isolator, battery switch, and the battery itself.

A 5 amp fuse located in the control box protects the battery charging circuits. No panel lights means a blown fuse.

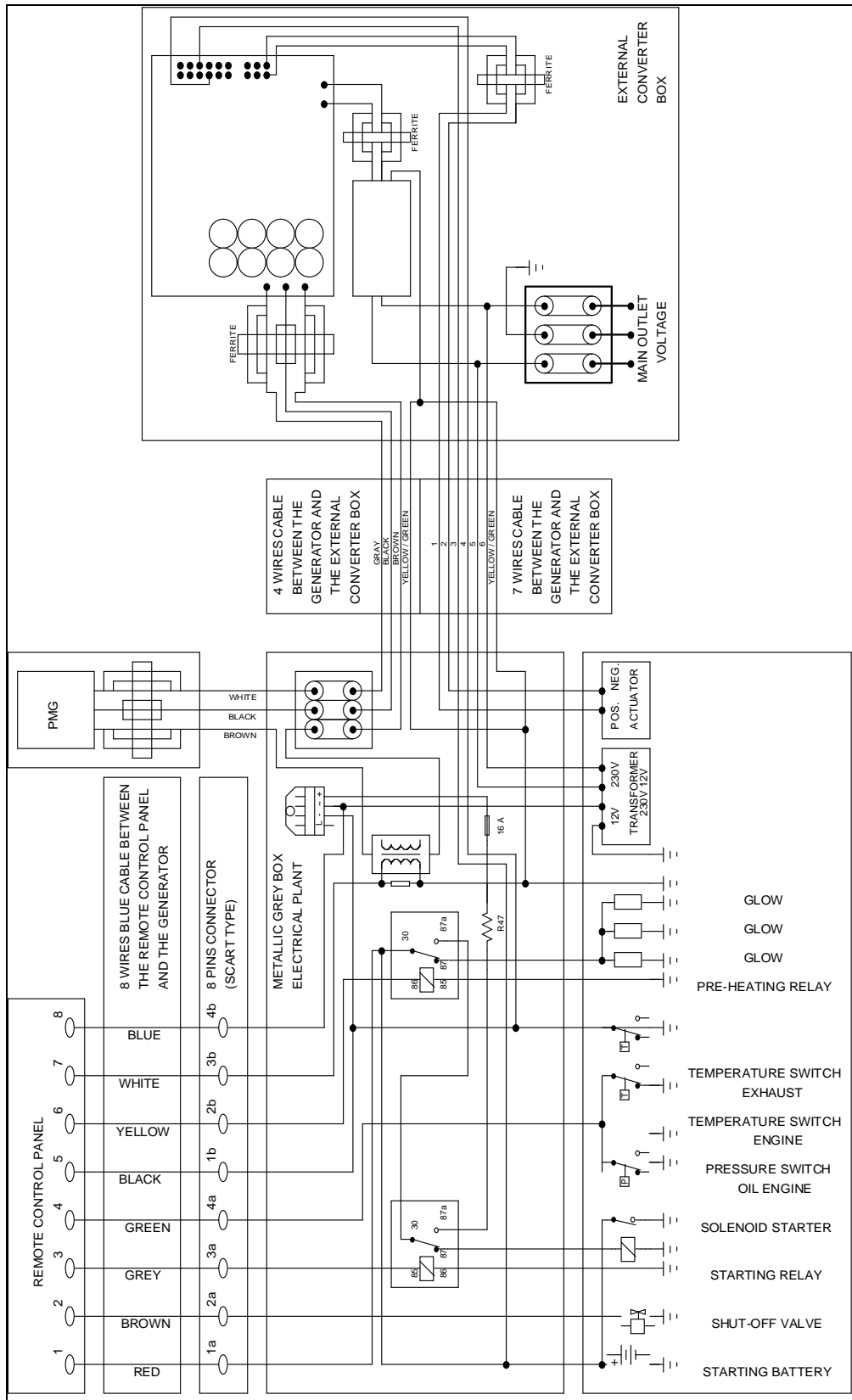

12. GENERATOR INFORMATION

GENERATOR MAINTENANCE

- Maintaining reasonable cleanliness is important. Connections of terminal boards and rectifiers may become corroded, and insulation surfaces may start conducting if salts, dust, engine exhaust, carbon, etc., are allowed to build up. Clogged ventilation openings may cause excessive heating and reduce life of windings.
- For unusually severe conditions, thin rust-inhibiting petroleum based coatings should be sprayed or brushed over all surfaces to reduce rusting and corrosion.
- In addition to periodic cleaning, the generator should be inspected for tightness of all connections, evidence of overheated terminals and loose or damaged wires.

VTE recommends mounting a carbon monoxide detector in the vessel's living quarters. Carbon monoxide, even in small amounts, is deadly.

The presence of carbon monoxide indicate an exhaust leak from the engine or generator or from the exhaust elbow/ exhaust hose, or that fumes from a nearby vessel are entering your boat.

If carbon monoxide is present, ventilate the area with clean air and correct the problem immediately.

13. GENERATOR TROUBLESHOOTING

Problem	Probable Cause	Remedy
Low no-load voltage	1. Engine speed too low. 2. Break down in windings.	1. Check and adjust rpm. 2. Check windings resistance.
Proper no load voltage but low voltage under load	1. Low loaded engine speed. 2. Overload.	1. Dirty fuel filter; replace. 2. Check the load indicator.
Unstable voltage	1. Loose contacts. 2. Uneven rotation.	1. Check connections. 2. Check for uniform rotation speed (dirty fuel filter).

14. SHORE POWER TRANSFER SWITCH

If the installer connects shore power to the vessel's AC circuit, this must be done by means of the Shore Power Transfer Switch. Set the transfer switch shown in the diagrams to the OFF position. This switch prevents simultaneous connections of shore power to generator output.

▲ CAUTION:

Damage to the generator can result if utility shore power and generator output are connected at the same time. This type of generator damage is not covered under the warranty; it is the installer's responsibility to make sure all AC connections are correct.

SWITCHING SHORE POWER TO GENERATOR POWER

▲ CAUTION:

Heavy motor loads should be shut-off before switching shore power to generator power or vice-versa because voltage surges induced by switching with heavy AC loads on the vessel being operated may cause damage to the exciter circuit components in the generator.

Both the lines or at least the generator line only, have to be protected with a magneto thermo safety switch, fitted on the main board panel. For your **PAGURO** choose a:

	230V 50cyc.
PAGURO 9000 v	35A
PAGURO 12000 v	44A

15. LAY-UP AND RECOMMISSIONING

GENERAL

Many owners rely on their boatyards to prepare their craft, including generators, for lay-up during the off season or for long periods of inactivity. Others prefer to accomplish lay-up preparation themselves.

The procedures which follow will allow you to perform your own lay-up and re-commissioning, or you may use them as a check list if others do the procedures.

These procedures should afford your engine protection during lay-up and also help familiarize you with the maintenance needs of your generator.

If you have any question regarding lay-up procedures, call your local servicing dealer; he will be more than willing to provide assistance.

LUBRICATING SYSTEM

With the engine warm, drain all the engine oil from the oil sump. Fill the sump with the correct amount of oil for your engine. Run the engine and check for proper oil pressure and make sure there are no leaks.

⚠ CAUTION: *Do not leave the engine's old engine oil in the sump over the lay-up period. Engine oil and combustion deposits combine to produce harmful chemicals which can reduce the life of your engine's internal parts.*

FUEL SYSTEM

Top off your fuel tanks with No.2 diesel fuel. Fuel additives should be added at this time to control algae and condition the fuel. Care should be taken that the additives used are compatible with the primary fuel filter/ water separator used in the system. Change the filter element in your primary fuel filter / water separator, if the fuel system has one, and clean the separator sediment bowl. Reinstall and make certain there are no leaks. Clean up any spilled fuel.

Change the fuel filter elements on the engine and bleed the fuel system, as needed. Start the engine and allow it to run for 5-10 minutes to make sure there is no air left in the fuel system. Check for any leaks that may have been created in the fuel system during this servicing, correcting them as needed. Operate the engine for 5-10 minutes. This will allow movement of the treated fuel through the injection equipment of the engine.

RAW WATER COOLING CIRCUIT

Close the through-hull fitting. Remove the raw water intake hose from the fitting. Place the end of this hose into a bucket of clean fresh water. Clean the raw water strainer.

Start the engine and allow the raw water pump to draw fresh through the system. When the bucket is empty, stop the engine and refill the bucket with an antifreeze solution slightly stronger than needed for winter freeze protection in your area.

Start the engine and allow all of this mixture to be drawn through the raw water system. Once the bucket is empty, stop the engine. This antifreeze mixture should protect the raw water circuit from freezing during the winter lay-up, as well as providing corrosion protection.

Remove the impeller from your water pump (some antifreeze mixture will accompany it, so catch it in a bucket). Examine the impeller. Acquire a replacement, if needed, and a cover gasket. Do not replace the impeller (into the pump) until re-commissioning, but replace the cover and gasket.

CYLINDER AND VALVES

To protect the cylinder and valves, remove the control box side cover. Then spray fogging oil into the cylinder head air intake opening. Rotate the engine two revolutions using the hand crank. Spray fogging oil into the air intake again. Replace the control box side cover.

STARTER MOTOR

Lubrication and cleaning of the starter drive pinion is advisable. Make sure the battery connections are shut off before attempting to remove the starter. Take care in properly replacing any electrical connections removed from the starter.

SPARE PARTS

Lay-up time provides a good opportunity to inspect your generator to see if external items such as drive belt or coolant hoses need replacement. Check your basic spares kit and order items not on hand, or replace those items used during the lay-up, such as filters.

BATTERIES

If batteries are to be left on board during the lay-up period, make sure they are fully charged, and will remain that way, to prevent them from freezing. If there is any doubt the batteries will not remain fully charged, or that they will be subjected to severe environmental conditions, remove the batteries and store them in a warmer, more compatible environment.

STORAGE

Thoroughly clean the outside of the generator, then store the generator in a dry place, protected against the weather.

RECOMMISSIONING

The recommissioning of your PAGURO generator after a seasonal lay-up generally follows the same procedures as those described in the PREPARATION FOR INITIAL START-UP section regarding preparation for starting and normal starts. However, some of the lay-up procedures will need to be counteracted before starting the engine.

1. Reinstall the batteries that were removed during the lay-up, and reconnect the battery cables, making sure the terminals are clean and that the connections are tight. Check to make sure that the batteries are fully charged.

⚠ CAUTION: *Wear rubber gloves, a rubber apron and eye protection when servicing batteries. Lead acid batteries emit hydrogen, a highly explosive gas, which can be ignited by electrical arcing or a lighted cigarette, cigar or pipe. Do not smoke or allow an open flame near the battery being serviced. Shut off all electrical equipment in the vicinity to prevent electrical arcing during servicing.*

2. Start the engine in accordance with the procedures described in the PREPARATIONS FOR INITIAL START-UP section of this manual.

